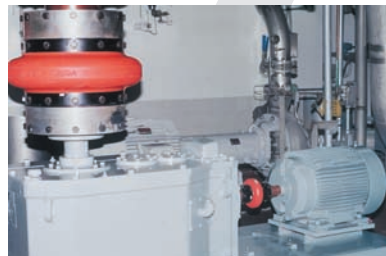


Couplings | Omega® Elastomer Couplings  
(English-Inch)



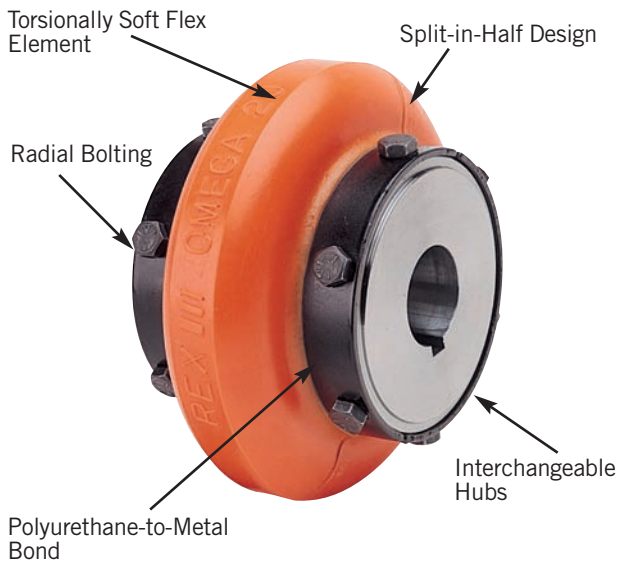
# Omega® Elastomeric Couplings

## OEM Performance and Coverage

The unique split-in-half flex element and reversible hubs significantly reduce total costs by reducing inventory and assembly time.

Rexnord Omega couplings are non-lubricated, material-flexing couplings utilizing a specially formulated polyurethane material engineered for maximum durability, strength and fatigue resistance.

## Features and Benefits



The Rex Omega HSU coupling (green) is specifically designed for hot and humid conditions.

Rexnord is the leading coupling provider in the industry with a full-line of available solutions supported by trained customer service and application engineering professionals focused only on our coupling product line. For more information, contact your local Rexnord account executive.

- Split-in-half flex element design for simplified assembly and disassembly
- Interchangeable hubs allow for reduced inventory
- High misalignment capacity accommodates unavoidable misalignment with low reactionary forces
- Torsionally soft flex element cushions shock loads and vibration extending equipment life
- Polyurethane flex element does not require lubrication
- Polyurethane-to-metal bond eliminates assembly and slippage problems associated with mechanically clamped designs
- Our selection software makes choosing the right coupling a snap
- Rexnord field specialists are locally based experts available to support key end-users
- The Rexnord Omega HSU coupling (green) is specifically designed for hot and humid environments.

In addition, the HSU material performs well in caustic and acidic environments. Consult Rexnord engineering for your application.

## TABLE OF CONTENTS

<b>DESCRIPTION</b>	<b>PAGE</b>
Installation and Misalignment Ratings	3
Standard Close Coupled Design	4–5
Spacer Design	6–8
Extended Spacer Design	9
Mill Motor Design	10
Special Designs	11
Selection	12–14
Bore Specifications and Finished Stock Bore Hubs	15
Ordering	16–17

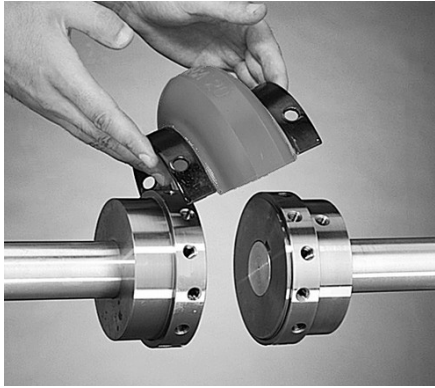


Rexnord Omega couplings operate in either horizontal or vertical applications without any additional components.

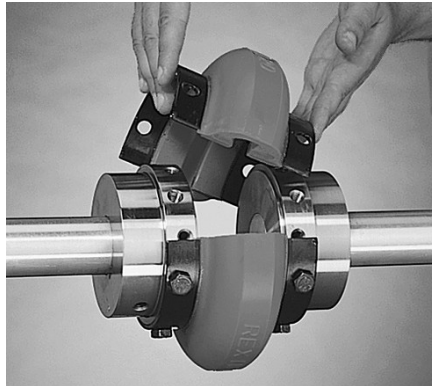
Ease of installation, ease of maintenance, and visual inspection make these couplings a must for many applications such as this mash cooker in a brewery. Never operate coupling without an OSHA approved guard.

# Omega® Elastomeric Couplings

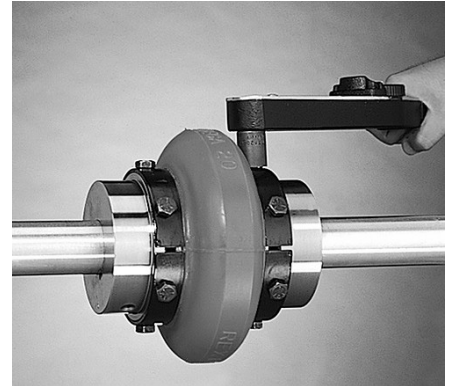
## INSTALLATION



Mount one hub to shaft, leave other hub loose for adjustment of spacing.

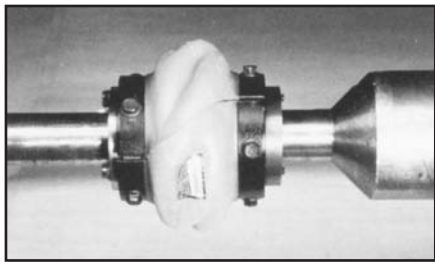


Place half of the Rexnord® Omega® element around hubs and secure with self-locking cap screws. Omega element will space the other hub. Now secure the other hub.



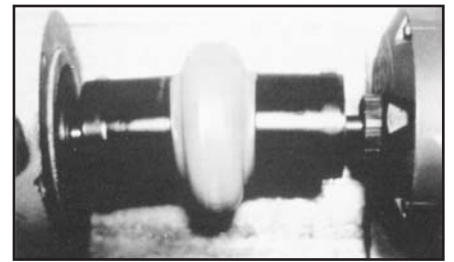
Mount other half of the Omega element. Tighten all cap screws to recommended torques below and you're done! Refer to the installation instruction for further details.

## TESTED TOUGH



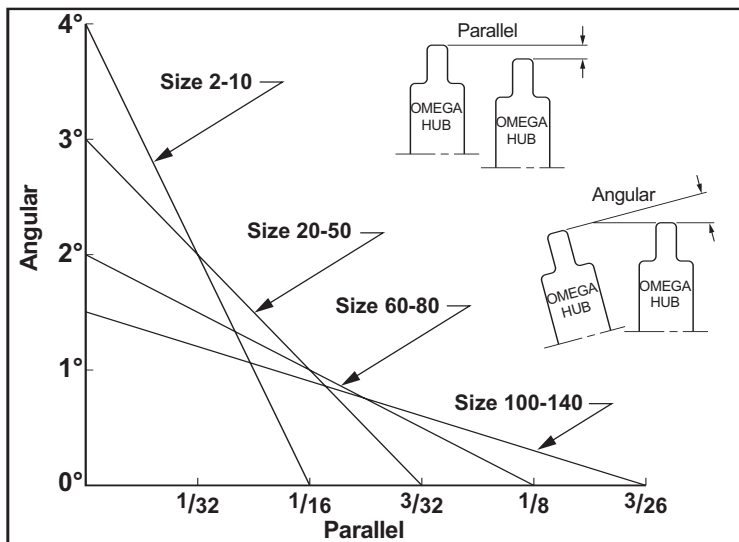
Severe static testing (5 x rating) shows element flexibility, rugged design and positive adhesive bond to the metal shoes.

Rigorous testing demonstrates that the Rexnord Omega coupling protects connected equipment from the damaging effects of misalignment, vibration and gross overload. Where other coupling designs might allow equipment damage, the super flexible element of Rexnord Omega couplings minimizes the reactionary forces on equipment bearings under severe misalignment conditions and reduces the effects of excessive shock overloads.



Demonstrates coupling's ability to accept severe misalignment.

## Omega® Coupling Allowable Misalignment



Note:

Any combination of parallel and angular misalignment which falls under the triangle will not cause a premature fatigue failure of the flexible element in normal use.

## — IMPORTANT — RECOMMENDED CAPSCREW TORQUE FOR PROPER INSTALLATION

Coupling Size	Torque – Dry	
	In. Lbs.	Ft. Lbs.
2	204	17
3		
4		
5		
10	360	30
20		
30		
40		
50	816	68
60		
70		
80		
100	3240	270
120		
140		
140	7080	590

NOTE: Capscrews have self locking patches which should not be reused more than twice. Capscrews can be further used if a thread locking adhesive is applied.

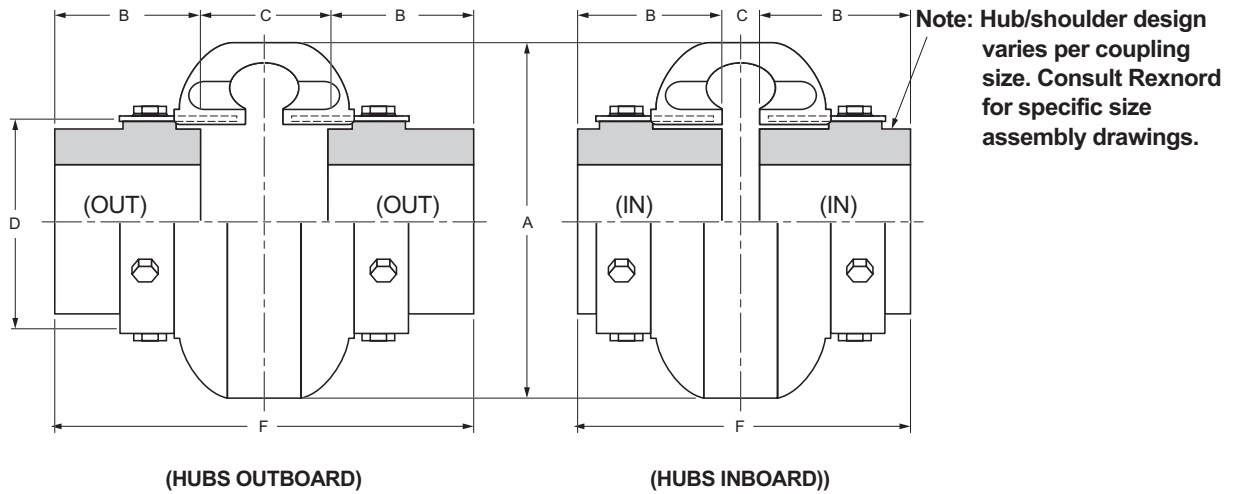
**Do NOT Lubricate Capscrew Threads**

### Important Note:

Coupling alignment is directly related to smooth, efficient equipment operation. Care should be taken for best possible alignment.

# REXNORD® OMEGA® STANDARD COUPLINGS

## WITH STRAIGHT BORE HUBS



Specification Data With Straight Bore Hubs

Omega Coupling Size	Recom. Max. Bore (In.)	① Continuous HP/100 RPM	① Continuous Torque (In. Lbs.)	Max. RPM	Dimensions In Inches							② Weight (Lb.)
					A	B	C		D	F		
							(In.)	(Out)		(In.)	(Out)	
E2	1.13	.30	190	7500	3.50	.94	1.34	1.90	1.85	3.22	3.78	1.2
E3	1.38	.58	365	7500	4.00	1.50	.81	1.31	2.32	3.81	4.31	2.4
E4	1.63	.88	550	7500	4.56	1.69	.44	1.31	2.60	3.81	4.69	3.0
E5	1.88	1.48	925	7500	5.38	1.75	.81	1.81	3.13	4.31	5.31	5.4
E10	2.13	2.30	1450	7500	6.38	1.88	.56	1.81	3.65	4.31	5.56	8.2
E20	2.38	3.65	2300	6600	7.25	2.06	.50	2.38	4.48	4.62	6.50	13.0
E30	2.88	5.79	3650	5800	8.25	2.31	.56	2.44	5.42	5.19	7.06	21.2
E40	3.38	8.85	5500	5000	9.50	2.50	.56	2.68	6.63	5.56	7.68	35
E50	3.63	12.14	7650	4200	11.00	2.75	.63	3.38	8.13	6.13	8.88	54
E60	4.00	19.84	12,500	3800	12.50	3.25	.69	3.44	8.75	7.19	9.94	72
E70	4.50	35.12	22,125	3600	14.00	3.62	.75	3.75	9.25	8.00	11.00	86
E80	6.00	62.70	39,500	2000	16.00	4.87	.75	5.00	11.25	10.50	14.75	170
E100	6.75	135	85,050	1900	21.00	5.50	1.75	3.75	14.13	12.75	14.75	244
E120	7.50	270	170,100	1800	25.00	6.00	2.25	4.88	17.63	14.24	16.88	425
E140	11.00	540	340,200	1500	30.00	7.00	3.00	5.00	20.88	17.00	19.00	746

① Service factor = 1.0

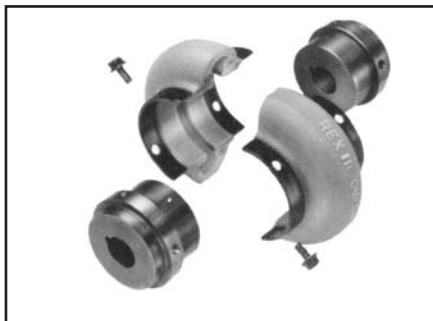
② With maximum bore hubs.

- SPLIT-IN-HALF FLEX ELEMENT**

Allows disassembly and replacement without disturbing hubs or connected equipment.

- REVERSIBLE HUBS**

Accommodates different shaft spacing requirements, and allows compression bushings to be installed from either side of the hub.



Straight Bore Hubs



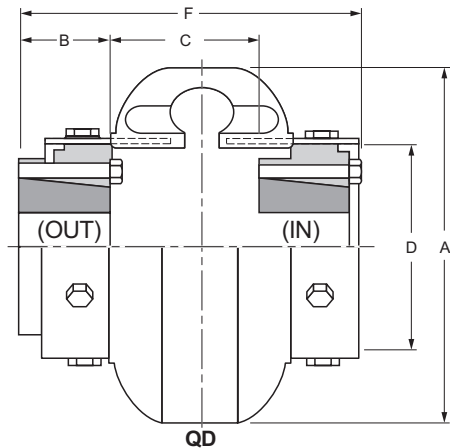
QD Hubs and Bushings



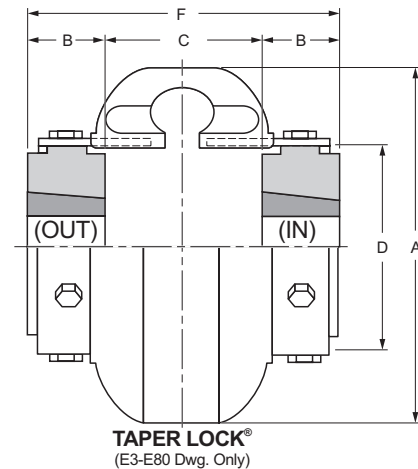
TAPER-LOCK® Hubs and Bushings

# REXNORD® OMEGA® STANDARD COUPLINGS

## WITH COMPRESSION BUSHED HUBS



NOTE: Bushings are NOT included with hubs



TAPER LOCK®  
(E3-E80 Dwg. Only)

Specification Data With QD Hubs

Omega Coupling Size	QD Bush. No.	① Recom. Max. Bore (In.)	② Continuous HP/100 RPM	② Continuous Torque (In. Lbs.)	Max. RPM	Dimensions In Inches						③ Weight (Lb.)	
						A	B	C		D	F		
								(In.) <sup>④</sup>	(Out)		(In.) <sup>④</sup>		(Out)
E4	JA	1.25	.88	550	7500	4.56	1.00	1.22	1.88	2.60	3.22	3.88	2.1
E5	SH	1.63	1.48	925	7500	5.38	1.25	1.75	1.88	3.13	4.25	4.50	3.6
E10	SDS	1.94	2.30	1450	7500	6.38	1.31	1.19	2.31	3.65	3.81	4.94	4.8
E20	SK	2.50	3.65	2300	6600	7.25	1.88	0.62	2.62	4.48	4.25	6.38	8.5
E30	SF	2.81	5.79	3650	5800	8.25	2.00	1.44	2.19	5.42	5.44	6.19	14.0
E40	E	3.50	8.85	5500	5000	9.50	2.63	1.25	1.75	6.63	6.50	7.00	23.8
E50	E	3.50	12.14	7650	4200	11.00	2.63	1.37	2.88	8.13	6.63	8.13	37.6
E60	F	3.94	19.84	12,500	3800	12.50	3.63	1.50	1.89	8.75	8.75	9.13	45.5
E70	J	4.50	35.12	22,125	3600	14.00	4.50	1.31	1.43	9.25	13.31	10.43	68.1
E80	M	5.50	62.70	39,500	2000	16.00	6.75	0.75	1.25	11.25	14.25	14.75	140
E100	M	5.50	135	85,050	1900	21.00	6.80	1.75	1.16	14.13	15.34	14.75	250
E120	N	6.00	270	150,000 <sup>⑥</sup>	1800	25.00	8.12	1.74	1.16	17.63	17.96	16.88	475
E140	P	7.00	540	250,000 <sup>⑥</sup>	1500	30.00	9.36	0.30	3.00	20.88	21.78	19.00	782

NOTE: Dimensions may vary depending on bushing manufacturer.

Specification Data With TAPER-LOCK® Hubs

Omega Coupling Size	TL Bush. No.	① Recom. Max. Bore (In.)	② Continuous HP/100 RPM	② Continuous Torque (In. Lbs.)	Max. RPM	Dimensions In Inches					③ Weight (Lb.)		
						A	B	C		D		F	
								(In.) <sup>④</sup>	(Out)				(In.) <sup>④</sup>
E3	1008	1.00	.58	365	7500	4.00	.88	1.68	2.32	3.44	1.8		
E4	1008	1.00	.88	550	7500	4.56	.88	1.68	2.60	3.44	2.6		
E5	1108	1.13	1.48	925	7500	5.38	.88	2.19	3.13	3.94	4.0		
E10	1310	1.44*	2.30	1450	7500	6.38	1.00	2.06	3.65	4.06	6.0		
E20	1610	1.69*	3.65	2300	6600	7.25	1.00	2.50	4.48	4.50	9.0		
E30	2012	2.12*	5.79	3650	5800	8.25	1.25	2.56	5.42	5.06	13.6		
E40	2517	2.69*	8.85	5500	5000	9.50	1.75	2.38	6.63	5.88	21.8		
E50	2517	2.69*	12.14	7650	4200	11.00	1.75	3.00	8.13	6.50	31.5		
E60	3020	3.25*	19.84	12,500	3800	12.50	2.00	3.31	8.75	7.31	46.6		
E70	3535	3.94	35.12	22,125	3600	14.00	3.50	2.38	9.25	9.38	66.7		
E80	4040	4.44	62.70	39,500	2000	16.00	4.00	3.75	11.25	11.75	82		
E100	4545	4.94	135	85,050	1900	21.00	4.50	(In.) <sup>④</sup> 1.50 (Out) 6.00	14.13	(In.) <sup>④</sup> 10.50 (Out) 15.00	250		
E120	5050	5.00	270	126,000 <sup>⑥</sup>	1800	25.00	5.00	2.00	7.13	17.63	12.00	17.13	408
E140	7060 <sup>⑤</sup>	7.00 <sup>⑤</sup>	540	340,200	1500	30.00	6.00	3.00	7.00	20.88	15.00	19.00	660

① With shallow keyway.

② Service factor = 1.0. This rating may be lower is limited by the bushing rating, particularly if severe service conditions exist. Consult bushing manufacturer.

③ Without compression bushings.

④ Inboard hub mounting (see drawing on page 4) requires bushing installation from coupling ends. Allow space (extra "B" dimension) between coupling ends and equipment for bushing assembly/disassembly. Reverse taper hubs are available; consult Rexnord.

⑤ A 8065 bushing hub with 8.00" max bore is also available. Consult Rexnord.

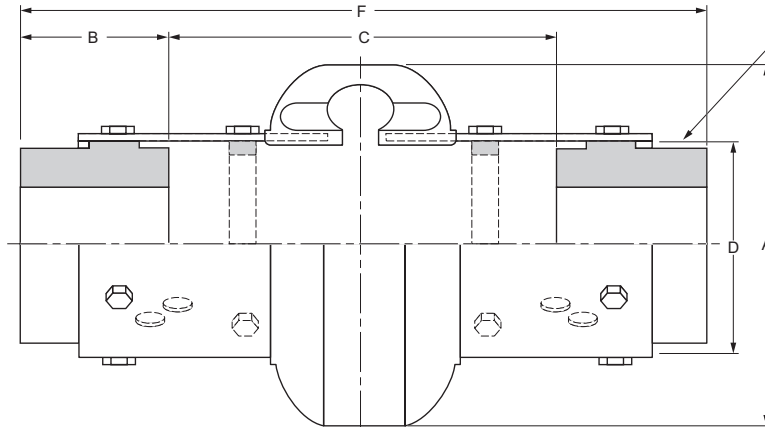
⑥ Maximum bushing rating.

\*With steel bushings

Note: Dimensions subject to change. Certified dimensions of ordered material furnished on request.

# REXNORD® OMEGA® SPACER COUPLINGS

## WITH STRAIGHT BORE HUBS



Note: Hub/shoulder design varies per coupling size. Consult Rexnord for specific size assembly drawings.

Specification Data With Straight Bore Hubs

① Omega Coupling Size	Recom. Max. Bore (In.)	② Continuous HP/100 RPM	② Continuous Torque (In. Lbs.)	③ Max. RPM	④ Dimensions In Inches							⑥ Weight (Lb.)
					A	B	C		D	F		
							(In.) <sup>④</sup>	(Out)		(In.) <sup>⑤</sup>	(Out)	
ES2-R	1.13	.30	190	7500	3.50	.94	3.50	4.00	1.85	5.75	5.92	2.3
ES3-R	1.38	.58	365	7500	4.00	1.50	3.50	5.00	2.32	7.25	8.00	4.0
ES4-R	1.63	.88	550	7500	4.56	1.69	3.50	5.00	2.60	7.25	8.38	5.1
ES5-R	1.88	1.48	925	7500	5.38	1.75	3.50	5.00	3.13	7.25	8.50	7.5
ES10-R	2.13	2.30	1450	7500	6.38	1.88	3.50	5.00	3.65	7.25	8.75	10.3
ES20	2.38	3.65	2300	4800	7.25	2.06	2.55	7.00	4.48	9.38	11.12	15.6
ES30	2.88	5.79	3650	4200	8.25	2.31	2.05	7.00	5.42	9.38	11.62	25.1
ES40	3.38	8.85	5500	3600	9.50	2.50	1.67	7.00	6.63	9.38	12.00	40
ES50	3.63	12.14	7650	3100	11.00	2.75	1.17	7.00	8.13	9.38	12.50	60
ES60	4.00	19.84	12,500	2800	12.50	3.25	2.67	9.75	8.75	12.50	16.25	84
ES70	4.50	35.12	22,125	2600	14.00	3.62	1.99	9.75	9.25	12.50	17.00	102
ES80	6.00	62.70	39,500	1800	16.00	4.87	2.18	9.75	11.25	12.50	19.50	180

① Suffix "R" designates high speed ring design. Rings are furnished standard for sizes ES2-R to ES10-R, optional for sizes ES20 to ES80.

② Service factor = 1.0.

③ Spacer coupling furnished with optional high speed rings (sizes ES20 to ES80) can be operated up to maximum allowable speeds for standard series couplings. See RPM Ratings on page 4.

④ Minimum shaft spacing is 0.25 inch. See page 8 for additional information.

⑤ Overall length of element.

⑥ With max bore hubs.

### • ADJUSTABLE SPACER DESIGN

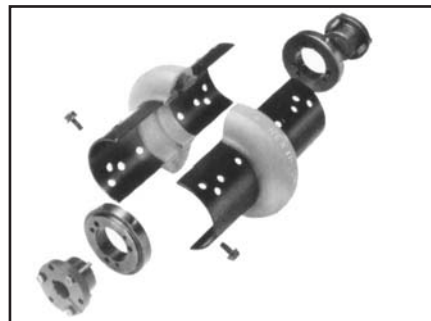
Optional hole mounting positions and reversible hub features allow adjustment to accommodate most shaft spacing requirements (see page 8)

### • UNIVERSAL HUBS

Straight bore and compression bushed hub designs are identical and interchangeable for both the spacer and standard couplings. This means maximum utilization of off the shelf inventory.



Straight Bore Hubs



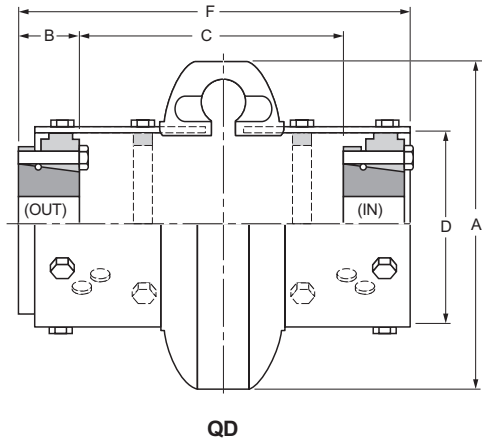
QD Hubs and Bushings



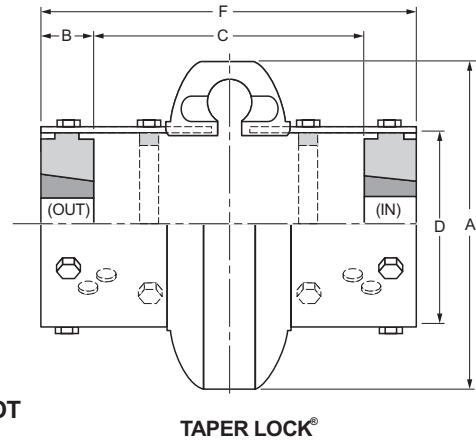
TAPER-LOCK® Hubs and Bushings

# REXNORD® OMEGA® SPACER COUPLINGS

## WITH COMPRESSION BUSHED HUBS



Note: Bushings are NOT included with hubs



Specification Data With QD Hubs

① Omega Spacer Size	QD Bush. No.	② Recom. Max. Bore (In.)	③ Continuous HP/100 RPM	③ Continuous Torque (In. Lbs.)	④ Max. RPM	Dimensions In Inches						⑥ Weight (Lb.)	
						A	B	C		D	F		
								(In.) <sup>⑤</sup>	(Out)		(In.)		(Out)
ES4-R	JA	1.25	.88	550	7500	4.56	1.00	3.24	5.56	2.60	7.25	7.71	4.2
ES5-R	SH	1.63	1.48	925	7500	5.38	1.25	3.51	5.06	3.13	7.25	7.82	5.7
ES10-R	SDS	1.94	2.30	1450	7500	6.38	1.31	3.60	5.49	3.65	7.25	8.24	6.9
ES20	SK	2.50	3.65	2300	4800	7.25	1.88	2.82	6.96	4.48	9.38	10.84	11.1
ES30	SF	2.94	5.79	3650	4200	8.25	2.00	3.36	6.44	5.42	9.38	10.32	17.9
ES40	E	3.44	8.85	5500	3600	9.50	2.63	2.94	5.74	6.63	9.38	10.71	28.8
ES50	E	3.44	12.14	7650	3100	11.00	2.63	2.44	6.24	8.13	9.38	11.21	43.6
ES60	F	3.94	19.84	12,500	2800	12.50	3.63	4.25	7.68	8.75	12.50	14.65	57.4
ES70	J	4.44	35.12	22,125	2600	14.00	4.50	3.50	6.72	9.25	12.52	15.40	84.1
ES80	M	5.50	62.70	39,500	1800	16.00	6.75	1.35	4.76	11.25	14.17	17.58	150.0

NOTE: Dimensions may vary depending on bushing manufacturer.

Specification Data With TAPER-LOCK® Hubs

① Omega Spacer Size	TL Bush. No.	② Recom. Max. Bore (In.)	③ Continuous HP/100 RPM	③ Continuous Torque (In. Lbs.)	④ Max. RPM	Dimensions In Inches						③ Weight (Lb.)	
						A	B	C		D	F		
								(In.) <sup>⑤</sup>	(Out)		(In.) <sup>⑤</sup>		(Out)
ES3-R	1008	1.00	.58	365	7500	4.00	.88	3.83	5.38	2.32	7.25	7.25	3.2
ES4-R	1008	1.00	.88	550	7500	4.56	.88	3.83	5.38	2.60	7.25	7.25	4.2
ES5-R	1108	1.13	1.48	925	7500	5.38	.88	3.83	5.38	3.13	7.25	7.25	6.0
ES10-R	1310	1.44*	2.30	1450	7500	6.38	1.00	3.71	5.25	3.65	7.25	7.25	7.9
ES20	1610	1.69*	3.65	2300	4800	7.25	1.00	4.84	6.75	4.48	9.38	9.38	11.9
ES30	2012	2.12*	5.79	3650	4200	8.25	1.25	4.59	6.50	5.42	9.38	9.38	18.0
ES40	2517	2.69*	8.85	5500	3600	9.50	1.75	4.09	6.00	6.63	9.38	9.59	26.8
ES50	2517	2.69*	12.14	7650	3100	11.00	1.75	4.09	6.00	8.13	9.38	9.59	37.4
ES60	3020	3.25*	19.84	12,500	2800	12.50	2.00	6.09	8.75	8.75	12.50	12.84	60.7
ES70	3535	3.94	35.12	22,125	2600	14.00	3.50	4.59	7.34	9.25	12.50	14.34	81.4
ES80	4040	4.44	62.70	39,500	1800	16.00	4.00	4.09	6.84	11.25	12.50	14.84	93.2

① Suffix "R" designates high speed ring design. Rings are furnished standard for sizes ES2-R to ES10-R, optional for sizes ES20 to ES80.

② With shallow keyway.

③ Service factor = 1.0. This rating is limited by the bushing rating.

④ Spacer coupling furnished with optional high speed rings (sizes ES20 to ES80) can be operated up to maximum allowable speeds for standard series couplings.

⑤ Minimum shaft spacing is 0.25 inch. See page 8 for additional information.

⑥ Without compression bushings.

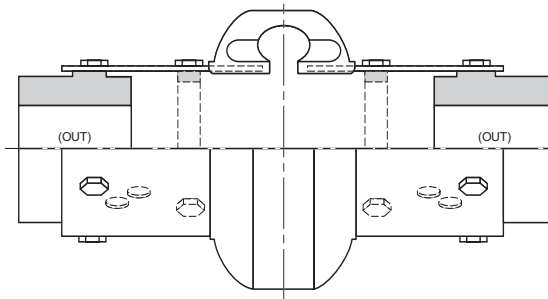
\* With steel bushings.

# REXNORD® OMEGA® SPACER COUPLINGS

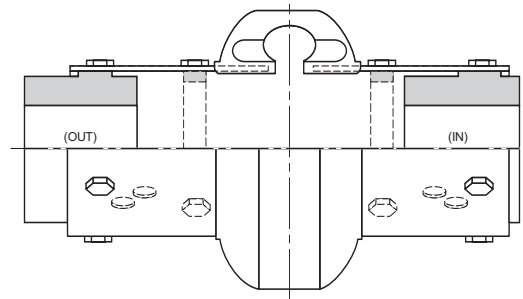
## “ADJUSTABILITY”

### SHAFT SPACING POSSIBILITIES (USING STRAIGHT BORE HUBS)

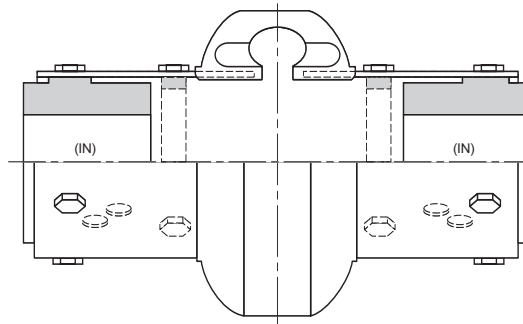
The Rexnord® Omega® spacer coupling design (pages 6-7) provides clear space between hubs. There are no interfering center members or spools which allows shaft spacing as small as 1/4"; however, for such small spacings, use of the standard Omega coupling would be recommended. The maximum shaft spacing for each coupling is shown on pages 6-7. Any ANSI, ISO or DIN spacing between 1/4 inch and the maximum listed can be achieved without any additional parts. Hubs can be placed on the shafts as shown below.



**Figure A**  
Both hubs mounted outboard

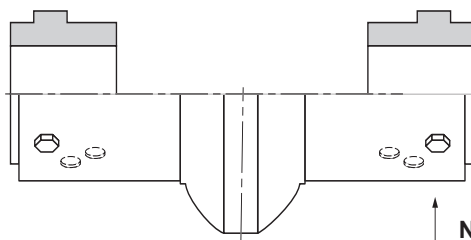


**Figure B**  
One hub mounted inboard  
One hub mounted outboard



**Figure C**  
Both hubs mounted inboard

Use one half of the flex element to establish shaft spacing and appropriate mounting position. Optional hole mounting positions and reversible hubs allow adjustments as needed. Select the combination which most closely matches the dimensions desired between shafts (Figure D). Drawings with specific mounting positions/dimensions are available from Rexnord.

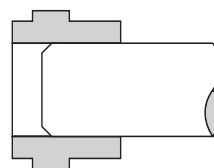


**Figure D**

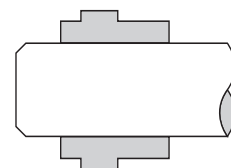
**Note: Optional capscrew hole mounting positions allow easy on-site adjustment to meet various shaft spacing requirements.**

Hubs can be flush with the shaft end (not shown), extended beyond the end of the shaft (Figure E) or recessed behind the shaft end provided there is sufficient keyway engagement (Figure F). Special sleeve extensions (see page 9) are available for spacing requirements in excess of those listed on pages 6-7.

**Note: Shaft engagement should be equal to or greater than .8 times shaft diameter. 100% shaft engagement is suggested for compression bushed hubs.**



**Figure E**



**Figure F**

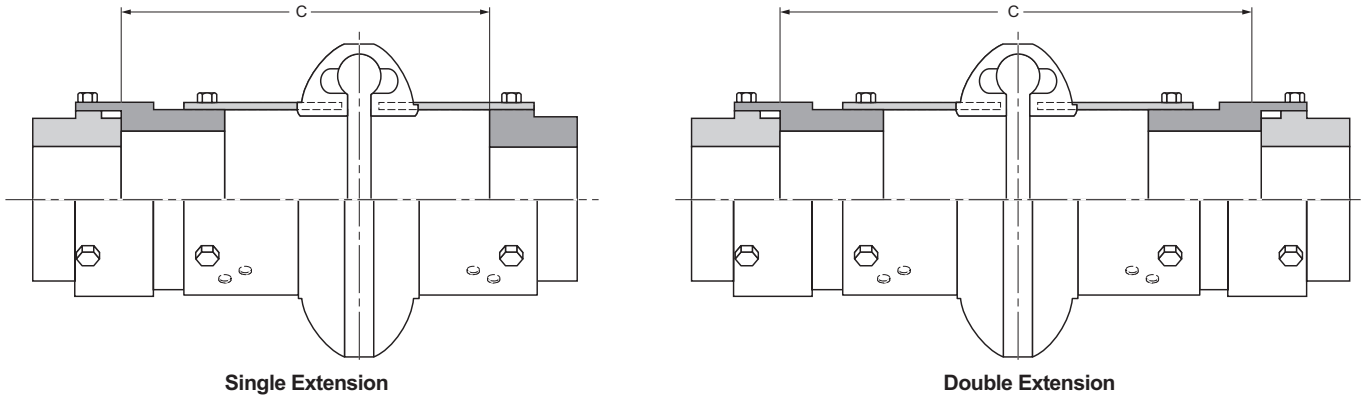


# REXNORD® OMEGA® SPACER COUPLINGS

## EXTENDED SPACER COUPLING

Rexnord® Omega® extended spacer couplings are designed to connect equipment with shaft spacing requirements beyond the Omega spacer coupling capabilities. They are ideal for applications with wide non-standard shaft gaps, and can be an economic alternative to floating shaft couplings (i.e. stock pump applications).

Sleeve extensions (“SE”) are furnished in steel. They mount to regular Omega spacer elements (standard elements for sizes E100 & E120) and cast iron or steel hubs – straight bore or compression bushed design. By adjusting the hub/shaft engagement (see figures E & F on page 8) and spacer element mounting position, the Omega extended spacer coupling can be utilized for many shaft spacing requirements.



Omega Spacer Size	Max. RPM Standard	② Max. RPM Matched Assembly	Maximum Spacing① – “C” Dimension – Inches									Weight (Lb.) One SE
			With SHRB Hubs			With HQD Hubs			With HTL Hubs			
			Max. Without SE	One SE	Two SE	Max. Without SE	One SE	Two SE	Max. Without SE	One SE	Two SE	
ES3-R	1800	3600	5.00	7.00	9.00	—	—	—	5.38	7.38	9.38	1.2
ES4-R	1800	3600	5.00	7.00	9.00	5.56	7.56	9.56	5.38	7.38	9.38	1.4
ES5-R	1800	3600	5.00	7.00	9.00	5.06	7.06	9.06	5.38	7.38	9.38	1.5
ES10-R	1800	3600	5.00	7.00	9.00	5.49	7.49	9.49	5.25	7.25	9.25	1.6
ES20	1800	3600	7.00	9.75	12.50	6.96	9.71	12.46	6.75	9.50	12.25	3.7
ES30	1800	3600	7.00	9.75	12.50	6.44	8.97	11.72	6.50	9.25	12.00	4.5
ES40	1800	3600	7.00	9.75	12.50	5.74	8.23	10.98	6.00	8.75	11.50	5.3
ES50	1800	3100	7.00	9.75	12.50	6.24	8.73	11.48	6.00	8.75	11.50	8.0
ES60	1800	2800	9.75	14.38	19.00	7.68	12.31	16.93	8.75	13.38	18.00	20.8
ES70	1800	2600	9.75	15.13	20.50	6.72	12.10	17.47	7.34	12.72	18.09	34.6
ES80	1500	1800	9.75	15.38	21.00	4.76	10.39	16.01	6.84	12.37	18.00	46.2
ES100	1500	1800	3.75	8.75	13.75	1.75	7.00	12.25	6.00	11.25	16.50	76.0
ES120	1500	1800	4.88	10.13	15.38	1.74	6.74	11.74	7.13	12.13	17.13	81.3

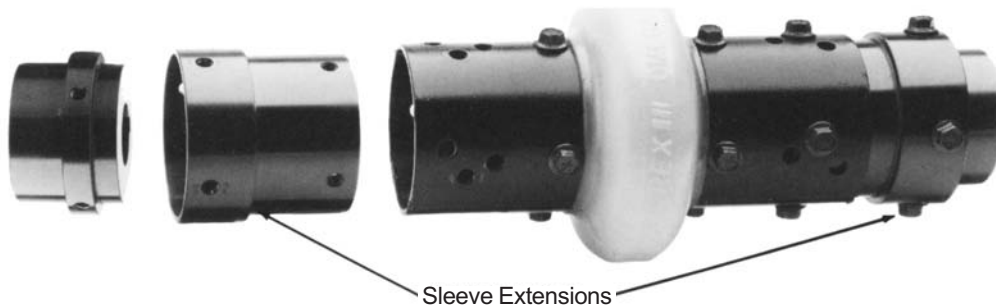
① Maximum spacings shown are with hubs mounted outboard and flush with shaft ends. Longer custom length extensions are available; consult Rexnord.

② Hub/sleeve extension assembly precisely machined and matched to obtain higher speed rating. Specify “Matched Assembly” when ordering.

**ORDERING INFORMATION:** When ordering, be sure to specify whether one of two sleeve extensions are required. If custom length, specify distance between shaft ends.

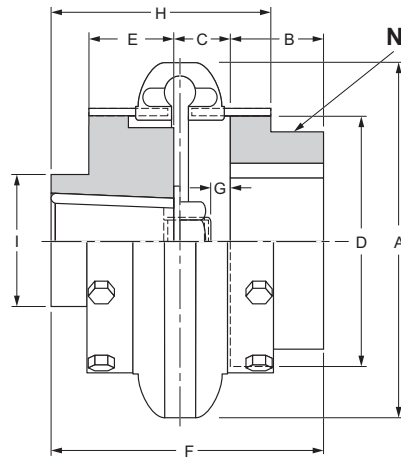
### • OPTIONAL SLEEVE EXTENSIONS (“SE”)

An economical alternative to floating shaft couplings (i.e., stock pump applications).



Note: Dimensions subject to change. Certified dimensions of ordered material furnished on request.

# REXNORD® OMEGA® MILL MOTOR COUPLINGS



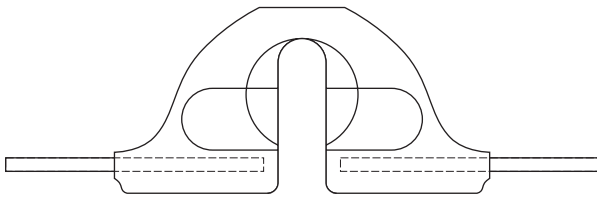
Note: Hub/shoulder design varies per coupling size. Consult Rexnord for specific size assembly drawings.

Mill Motor Coupling Dimensions

Coupling Size	Mill Motor Size	Max. RPM	① Continuous HP/100 RPM	Complete Coupling Weight, (Lb.)	Dimensions									Max. Straight Bore																																																																																																																																														
					A	B	C	D	E	F	G	H	I																																																																																																																																															
10	802A 602	7500	2.3	15.6	6 <sup>3</sup> / <sub>8</sub>	1 <sup>7</sup> / <sub>8</sub>	1 <sup>9</sup> / <sub>32</sub>	3 <sup>5</sup> / <sub>8</sub>	3	6 <sup>5</sup> / <sub>32</sub>	1 <sup>1</sup> / <sub>32</sub>	3 <sup>3</sup> / <sub>16</sub>	2 <sup>7</sup> / <sub>8</sub>	2 <sup>1</sup> / <sub>8</sub>																																																																																																																																														
20	802B 802C	6600	3.65	25.4	7 <sup>1</sup> / <sub>4</sub>	2 <sup>1</sup> / <sub>16</sub>	1 <sup>5</sup> / <sub>8</sub>	4 <sup>1</sup> / <sub>2</sub>	3	6 <sup>11</sup> / <sub>16</sub>	9 <sup>9</sup> / <sub>16</sub>	4 <sup>1</sup> / <sub>4</sub>	3	2 <sup>3</sup> / <sub>8</sub>																																																																																																																																														
	3 <sup>1</sup> / <sub>2</sub>								6 <sup>3</sup> / <sub>8</sub>	1 <sup>1</sup> / <sub>2</sub>																																																																																																																																																		
30	803 804 603 604	5800	5.79	39.3	8 <sup>1</sup> / <sub>4</sub>	2 <sup>5</sup> / <sub>16</sub>	1 <sup>1</sup> / <sub>2</sub>	5 <sup>7</sup> / <sub>16</sub>	3 <sup>1</sup> / <sub>2</sub>	7 <sup>5</sup> / <sub>16</sub>	5 <sup>5</sup> / <sub>8</sub>	4 <sup>9</sup> / <sub>16</sub>	3 <sup>1</sup> / <sub>2</sub>	2 <sup>7</sup> / <sub>8</sub>																																																																																																																																														
	40														804 604	5000	8.85	58.0	9 <sup>1</sup> / <sub>2</sub>	2 <sup>1</sup> / <sub>2</sub>	1 <sup>1</sup> / <sub>2</sub>	6 <sup>5</sup> / <sub>8</sub>	3 <sup>1</sup> / <sub>2</sub>	7 <sup>1</sup> / <sub>2</sub>	1 <sup>1</sup> / <sub>2</sub>	4 <sup>7</sup> / <sub>8</sub>	3 <sup>1</sup> / <sub>2</sub>	3 <sup>3</sup> / <sub>8</sub>	50	406 806 606	4200	12.14	83.5	11	2 <sup>3</sup> / <sub>4</sub>	1 <sup>13</sup> / <sub>16</sub>	8 <sup>1</sup> / <sub>8</sub>	4	8 <sup>9</sup> / <sub>16</sub>	1 <sup>11</sup> / <sub>16</sub>	5 <sup>1</sup> / <sub>2</sub>	4	3 <sup>5</sup> / <sub>8</sub>	408 608	4 <sup>1</sup> / <sub>2</sub>	9 <sup>1</sup> / <sub>16</sub>	9 <sup>9</sup> / <sub>16</sub>	60	406 806 408 608	3800	19.84	120.3	12 <sup>1</sup> / <sub>2</sub>	3 <sup>1</sup> / <sub>4</sub>	1 <sup>3</sup> / <sub>4</sub>	8 <sup>3</sup> / <sub>4</sub>	4	9	5 <sup>5</sup> / <sub>8</sub>	6 <sup>5</sup> / <sub>16</sub>	4 <sup>1</sup> / <sub>2</sub>	4	4 <sup>1</sup> / <sub>2</sub>	9 <sup>1</sup> / <sub>2</sub>	1 <sup>1</sup> / <sub>2</sub>	70	408 808 608 410 810 610	3600	35.12	150	14	3 <sup>5</sup> / <sub>8</sub>	2 <sup>1</sup> / <sub>2</sub>	9 <sup>1</sup> / <sub>4</sub>	4 <sup>1</sup> / <sub>2</sub>	10 <sup>5</sup> / <sub>8</sub>	1 <sup>1</sup> / <sub>4</sub>	6 <sup>7</sup> / <sub>8</sub>	4 <sup>3</sup> / <sub>4</sub>	4 <sup>1</sup> / <sub>2</sub>	412 612	5	11 <sup>11</sup> / <sub>16</sub>	1	80	410 810 412 812 612 614	2000	62.7	235	16	4 <sup>7</sup> / <sub>8</sub>	3 <sup>1</sup> / <sub>8</sub>	11 <sup>1</sup> / <sub>4</sub>	4 <sup>1</sup> / <sub>2</sub>	12 <sup>1</sup> / <sub>2</sub>	1 <sup>3</sup> / <sub>4</sub>	9 <sup>1</sup> / <sub>4</sub>	6	6	5	13	1 <sup>9</sup> / <sub>16</sub>	100	812 614 814 616 816 618 818	1900	135	340	21	5 <sup>1</sup> / <sub>2</sub>	3 <sup>3</sup> / <sub>4</sub>	14 <sup>1</sup> / <sub>8</sub>	5	14 <sup>1</sup> / <sub>4</sub>	2 <sup>1</sup> / <sub>8</sub>	9 <sup>3</sup> / <sub>4</sub>	10 <sup>1</sup> / <sub>4</sub>	6 <sup>3</sup> / <sub>4</sub>	5 <sup>1</sup> / <sub>2</sub>	14 <sup>3</sup> / <sub>4</sub>	2	120	818 620	1800	270	520	25	6	4 <sup>7</sup> / <sub>8</sub>	17 <sup>5</sup> / <sub>8</sub>	6	16 <sup>7</sup> / <sub>8</sub>	3 <sup>9</sup> / <sub>16</sub>	11 <sup>9</sup> / <sub>16</sub>	11 <sup>3</sup> / <sub>4</sub>	7 <sup>1</sup> / <sub>2</sub>	6	16 <sup>7</sup> / <sub>8</sub>	3 <sup>1</sup> / <sub>8</sub>	140	622 624	1500	540	950	30	7	5	20 <sup>7</sup> / <sub>8</sub>	7	19	2 <sup>5</sup> / <sub>8</sub>	13	15	9	7	19	2 <sup>5</sup> / <sub>8</sub>
															40															804 604								5000	8.85	58.0				9 <sup>1</sup> / <sub>2</sub>	2 <sup>1</sup> / <sub>2</sub>	1 <sup>1</sup> / <sub>2</sub>	6 <sup>5</sup> / <sub>8</sub>		3 <sup>1</sup> / <sub>2</sub>								7 <sup>1</sup> / <sub>2</sub>	1 <sup>1</sup> / <sub>2</sub>	4 <sup>7</sup> / <sub>8</sub>				3 <sup>1</sup> / <sub>2</sub>	3 <sup>3</sup> / <sub>8</sub>	50		406 806 606								4200	12.14	83.5				11	2 <sup>3</sup> / <sub>4</sub>	1 <sup>13</sup> / <sub>16</sub>	8 <sup>1</sup> / <sub>8</sub>		4								8 <sup>9</sup> / <sub>16</sub>	1 <sup>11</sup> / <sub>16</sub>	5 <sup>1</sup> / <sub>2</sub>				4	3 <sup>5</sup> / <sub>8</sub>	408 608		4 <sup>1</sup> / <sub>2</sub>								9 <sup>1</sup> / <sub>16</sub>	9 <sup>9</sup> / <sub>16</sub>	60				406 806 408 608	3800	19.84		120.3								12 <sup>1</sup> / <sub>2</sub>	3 <sup>1</sup> / <sub>4</sub>	1 <sup>3</sup> / <sub>4</sub>				8 <sup>3</sup> / <sub>4</sub>	4	9		5 <sup>5</sup> / <sub>8</sub>								6 <sup>5</sup> / <sub>16</sub>	4 <sup>1</sup> / <sub>2</sub>	4				4 <sup>1</sup> / <sub>2</sub>	9 <sup>1</sup> / <sub>2</sub>	1 <sup>1</sup> / <sub>2</sub>
40	804 604	5000	8.85	58.0	9 <sup>1</sup> / <sub>2</sub>	2 <sup>1</sup> / <sub>2</sub>	1 <sup>1</sup> / <sub>2</sub>	6 <sup>5</sup> / <sub>8</sub>	3 <sup>1</sup> / <sub>2</sub>	7 <sup>1</sup> / <sub>2</sub>	1 <sup>1</sup> / <sub>2</sub>	4 <sup>7</sup> / <sub>8</sub>	3 <sup>1</sup> / <sub>2</sub>	3 <sup>3</sup> / <sub>8</sub>																																																																																																																																														
	50														406 806 606	4200	12.14	83.5	11	2 <sup>3</sup> / <sub>4</sub>	1 <sup>13</sup> / <sub>16</sub>	8 <sup>1</sup> / <sub>8</sub>	4	8 <sup>9</sup> / <sub>16</sub>	1 <sup>11</sup> / <sub>16</sub>	5 <sup>1</sup> / <sub>2</sub>	4	3 <sup>5</sup> / <sub>8</sub>	408 608	4 <sup>1</sup> / <sub>2</sub>	9 <sup>1</sup> / <sub>16</sub>	9 <sup>9</sup> / <sub>16</sub>	60	406 806 408 608	3800	19.84	120.3	12 <sup>1</sup> / <sub>2</sub>	3 <sup>1</sup> / <sub>4</sub>	1 <sup>3</sup> / <sub>4</sub>	8 <sup>3</sup> / <sub>4</sub>	4	9	5 <sup>5</sup> / <sub>8</sub>	6 <sup>5</sup> / <sub>16</sub>	4 <sup>1</sup> / <sub>2</sub>	4	4 <sup>1</sup> / <sub>2</sub>	9 <sup>1</sup> / <sub>2</sub>	1 <sup>1</sup> / <sub>2</sub>	70	408 808 608 410 810 610	3600	35.12	150	14	3 <sup>5</sup> / <sub>8</sub>	2 <sup>1</sup> / <sub>2</sub>	9 <sup>1</sup> / <sub>4</sub>	4 <sup>1</sup> / <sub>2</sub>	10 <sup>5</sup> / <sub>8</sub>	1 <sup>1</sup> / <sub>4</sub>	6 <sup>7</sup> / <sub>8</sub>	4 <sup>3</sup> / <sub>4</sub>	4 <sup>1</sup> / <sub>2</sub>	412 612	5	11 <sup>11</sup> / <sub>16</sub>	1	80	410 810 412 812 612 614	2000	62.7	235	16	4 <sup>7</sup> / <sub>8</sub>	3 <sup>1</sup> / <sub>8</sub>	11 <sup>1</sup> / <sub>4</sub>	4 <sup>1</sup> / <sub>2</sub>	12 <sup>1</sup> / <sub>2</sub>	1 <sup>3</sup> / <sub>4</sub>	9 <sup>1</sup> / <sub>4</sub>	6	6	5	13	1 <sup>9</sup> / <sub>16</sub>	100	812 614 814 616 816 618 818	1900	135	340	21	5 <sup>1</sup> / <sub>2</sub>	3 <sup>3</sup> / <sub>4</sub>	14 <sup>1</sup> / <sub>8</sub>	5	14 <sup>1</sup> / <sub>4</sub>	2 <sup>1</sup> / <sub>8</sub>	9 <sup>3</sup> / <sub>4</sub>	10 <sup>1</sup> / <sub>4</sub>	6 <sup>3</sup> / <sub>4</sub>	5 <sup>1</sup> / <sub>2</sub>	14 <sup>3</sup> / <sub>4</sub>	2	120	818 620	1800	270	520	25	6	4 <sup>7</sup> / <sub>8</sub>	17 <sup>5</sup> / <sub>8</sub>	6	16 <sup>7</sup> / <sub>8</sub>	3 <sup>9</sup> / <sub>16</sub>	11 <sup>9</sup> / <sub>16</sub>	11 <sup>3</sup> / <sub>4</sub>	7 <sup>1</sup> / <sub>2</sub>	6	16 <sup>7</sup> / <sub>8</sub>	3 <sup>1</sup> / <sub>8</sub>	140	622 624	1500	540	950	30	7	5	20 <sup>7</sup> / <sub>8</sub>	7	19	2 <sup>5</sup> / <sub>8</sub>	13	15	9	7	19	2 <sup>5</sup> / <sub>8</sub>															
50		406 806 606	4200	12.14	83.5	11	2 <sup>3</sup> / <sub>4</sub>	1 <sup>13</sup> / <sub>16</sub>	8 <sup>1</sup> / <sub>8</sub>	4	8 <sup>9</sup> / <sub>16</sub>	1 <sup>11</sup> / <sub>16</sub>	5 <sup>1</sup> / <sub>2</sub>	4	3 <sup>5</sup> / <sub>8</sub>																																																																																																																																													
	408 608	4 <sup>1</sup> / <sub>2</sub>								9 <sup>1</sup> / <sub>16</sub>	9 <sup>9</sup> / <sub>16</sub>																																																																																																																																																	
60	406 806 408 608	3800	19.84	120.3	12 <sup>1</sup> / <sub>2</sub>	3 <sup>1</sup> / <sub>4</sub>	1 <sup>3</sup> / <sub>4</sub>	8 <sup>3</sup> / <sub>4</sub>	4	9	5 <sup>5</sup> / <sub>8</sub>	6 <sup>5</sup> / <sub>16</sub>	4 <sup>1</sup> / <sub>2</sub>	4																																																																																																																																														
	4 <sup>1</sup> / <sub>2</sub>								9 <sup>1</sup> / <sub>2</sub>	1 <sup>1</sup> / <sub>2</sub>																																																																																																																																																		
70	408 808 608 410 810 610	3600	35.12	150	14	3 <sup>5</sup> / <sub>8</sub>	2 <sup>1</sup> / <sub>2</sub>	9 <sup>1</sup> / <sub>4</sub>	4 <sup>1</sup> / <sub>2</sub>	10 <sup>5</sup> / <sub>8</sub>	1 <sup>1</sup> / <sub>4</sub>	6 <sup>7</sup> / <sub>8</sub>	4 <sup>3</sup> / <sub>4</sub>	4 <sup>1</sup> / <sub>2</sub>																																																																																																																																														
	412 612								5	11 <sup>11</sup> / <sub>16</sub>	1																																																																																																																																																	
80	410 810 412 812 612 614	2000	62.7	235	16	4 <sup>7</sup> / <sub>8</sub>	3 <sup>1</sup> / <sub>8</sub>	11 <sup>1</sup> / <sub>4</sub>	4 <sup>1</sup> / <sub>2</sub>	12 <sup>1</sup> / <sub>2</sub>	1 <sup>3</sup> / <sub>4</sub>	9 <sup>1</sup> / <sub>4</sub>	6	6																																																																																																																																														
	5								13	1 <sup>9</sup> / <sub>16</sub>																																																																																																																																																		
100	812 614 814 616 816 618 818	1900	135	340	21	5 <sup>1</sup> / <sub>2</sub>	3 <sup>3</sup> / <sub>4</sub>	14 <sup>1</sup> / <sub>8</sub>	5	14 <sup>1</sup> / <sub>4</sub>	2 <sup>1</sup> / <sub>8</sub>	9 <sup>3</sup> / <sub>4</sub>	10 <sup>1</sup> / <sub>4</sub>	6 <sup>3</sup> / <sub>4</sub>																																																																																																																																														
	5 <sup>1</sup> / <sub>2</sub>								14 <sup>3</sup> / <sub>4</sub>	2																																																																																																																																																		
120	818 620	1800	270	520	25	6	4 <sup>7</sup> / <sub>8</sub>	17 <sup>5</sup> / <sub>8</sub>	6	16 <sup>7</sup> / <sub>8</sub>	3 <sup>9</sup> / <sub>16</sub>	11 <sup>9</sup> / <sub>16</sub>	11 <sup>3</sup> / <sub>4</sub>	7 <sup>1</sup> / <sub>2</sub>																																																																																																																																														
	6								16 <sup>7</sup> / <sub>8</sub>	3 <sup>1</sup> / <sub>8</sub>																																																																																																																																																		
140	622 624	1500	540	950	30	7	5	20 <sup>7</sup> / <sub>8</sub>	7	19	2 <sup>5</sup> / <sub>8</sub>	13	15	9																																																																																																																																														
	7								19	2 <sup>5</sup> / <sub>8</sub>																																																																																																																																																		

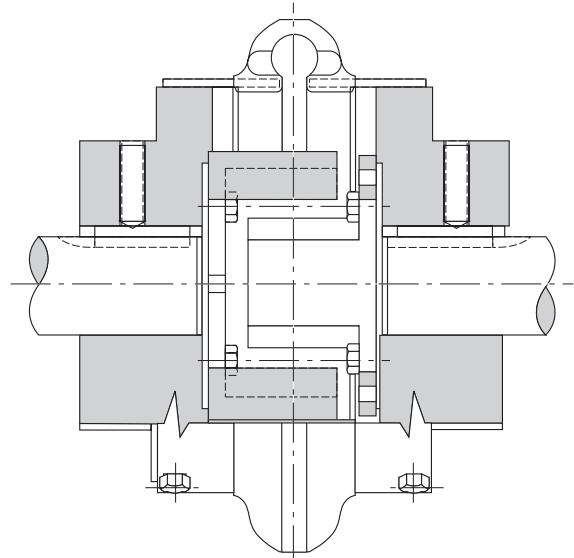
① Service Factor - 1.0

SPECIAL DESIGNS\*



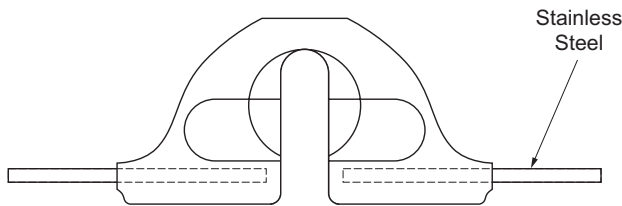
**REXNORD® OMEGA® HSU ELEMENT**

Hydrolytically Stable Urethane for superior resistance to hot and humid conditions in addition to acidic and alkaline environments. The Omega HSU element is interchangeable with existing hubs.



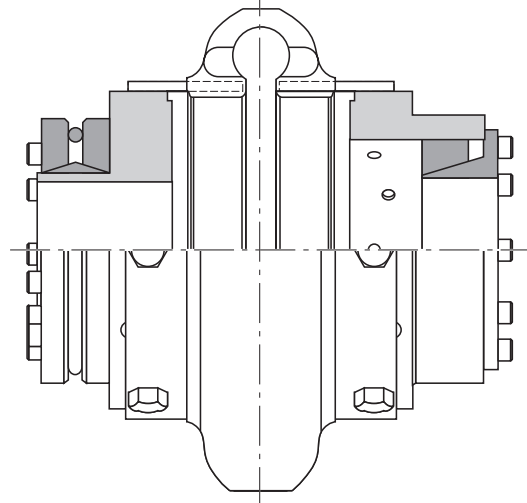
**REXNORD® OMEGA® POSITIVE DRIVE COUPLING**

With interlocking drive fail safe requirements.



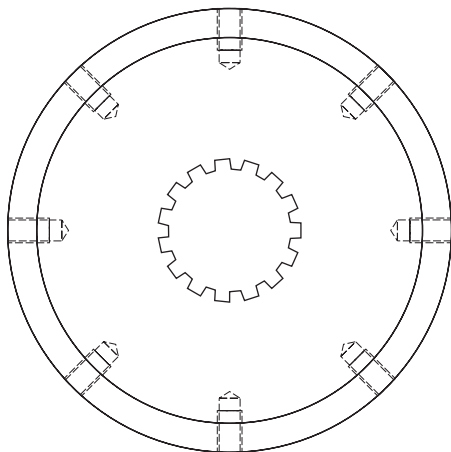
**REXNORD® OMEGA® STAINLESS STEEL ELEMENT**

Corrosion resistant 303/304 stainless steel shoes for severe environments. Stainless steel hubs also available.



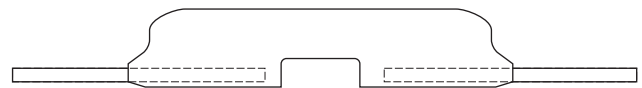
**REXNORD® OMEGA® KEYLESS HUB/BUSHING DESIGN**

Several optional keyless Hub/Bushing designs are available for increased bore end shaft gap requirements.



**REXNORD® OMEGA® SPLINE BORE HUB**

1. Number of Teeth – Ex. 14T
2. Pitch Fraction – Ex. 12/24 Pitch
3. Pressure Angle – 30° P.A.
4. Type of Tooth Shape – Ex. Involute or Straight Side
5. Type of Root – Ex. Fillet or Flat Root
6. Tolerance – Ex. Class I thru VII
7. Type of Fit – Ex. Side Fit or Major Diameter Fit



**REXNORD® OMEGA® LIGHT DUTY ELEMENT**

Available in size E2LD only. Minimum O.D. (2.5") for low profile applications. Max torque rating of 100 In. Lbs.

# REXNORD® OMEGA® COUPLINGS

## SELECTION PROCEDURES

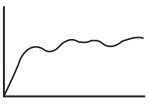
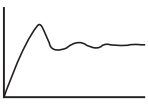
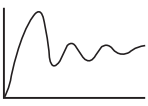
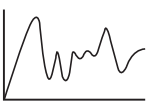
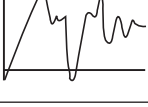
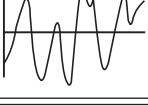
- Determine HP/100RPM:**  $HP/100 \text{ RPM} = \frac{\text{Horsepower} \times 100}{\text{RPM}}$
- Determine Service Factor:**  
Select the proper Service Factor from Table on page 13. If not listed, see Load Classification Table.  
Remember to consider both driver and driven equipment and temperature requirements.
- Multiply HP/100 by the service factor to get equivalent HP/100 RPM.**
- Select the Coupling Size:**  
From Table 1, with a rating equal to or greater than the equivalent HP/100 RPM determined in Step 3.
- Check Limiting Conditions:**  
Be sure that the operating speed of the coupling does not exceed maximum RPM listed on page 4-7.
- Select Desired Hub Type:**  
Select desired hub type and check maximum allowable coupling bore on page 14.

**OR**

- Determine Operating Torque:**  $\left( \frac{63,000 \times \text{HP}}{\text{RPM}} \right)$
- Multiply by Service Factor**  
Select the proper Service Factor from Table on page 13.
- Select the Coupling Size:**  
Select coupling size from Table 2 with a capacity equal to or greater than determined in Step 2.
- Follow Steps 5 & 6 Above**

### SERVICE FACTORS

**Service Factors** are a means of classifying different equipment and applications into various load classifications. Due to variations in application of equipment, service factors are used to adjust equipment ratings to accommodate for variable loading conditions. This is a general guide. More specific factors are given on page 13.

	Load Classifications	Service Factors
	Continuous service and running loads vary only slightly.	1.0
	Torque loading varies during operation of the equipment.	1.5
	Torque loading varies during operation, frequent stop/start cycles are encountered.	2.0
	For shock loading and substantial torque variations.	2.5
	For heavy shock loading or light reversing drives.	3.0
	Reversing torque loads do not necessarily mean reversal of rotation. Depending upon severity of torque reversal, such loads must be classified between "medium" and "extreme."	Consult Rexnord

**Omega® Element  
Temperature Range  
(Ambient)**

-40°F	to	+200°F
-40°C		+93°C

High Temperature Service Factor  
Adjustment\*

Ambient Temp.	S.F. Adjust.
+150°F (66°C)	+.025
+165°F (74°C)	+.050
+180°F (82°C)	+.075
+200°F (93°C)	+1.00

**Table 1**

Size		Equivalent HP/100 RPM
Standard	Spacer	
E2	ES2	.30
E3	ES3	.58
E4	ES4	.88
E5	ES5	1.48
E10	ES10	2.30
E20	ES20	3.65
E30	ES30	5.79
E40	ES40	8.85
E50	ES50	12.14
E60	ES60	19.84
E70	ES70	35.12
E80	ES80	62.70
E100	NA	135
E120	NA	270
E140	NA	540

**Table 2**

Torque Capacity			
Size	Continuous		Continuous
	Size	Torque (In. Lbs.)	
2	190	40	5,500
3	365	50	7,650
4	550	60	12,500
5	925	70	22,125
10	1,450	E0	39,500
20	2,300	100	85,050
30	3,650	120	170,100
		140	340,200

*The service factor adjustment for high temperature is in addition to the service factor consideration for the driver and driven equipment. However, if high temperatures are typical for a specific application, maximum temperature consideration is incorporated into the "typical" service factor listing on page 13. i.e., steel mill runout tables.*

# REXNORD® OMEGA® COUPLINGS SELECTION

## TYPICAL SERVICE FACTORS – MOTOR AND TURBINE DRIVEN EQUIPMENT ①

General Application	Typical Service Factor	Industry Application (cont'd)	Typical Service Factor
<b>AGITATORS</b>		<b>FOOD INDUSTRY</b>	
Vertical and Horizontal Screw Propeller, Paddle . . . . .	1.5	Bottle and Can Filling . . . . .	1.0
<b>BLOWERS</b>		Cereal Cooker . . . . .	1.0
Centrifugal . . . . .	1.0	Dough Mixer, Meat Grinder . . . . .	2.0
Lobe or Vane . . . . .	1.5	<b>LUMBER INDUSTRY</b>	
<b>CAR DUMPER AND PULLER</b> . . . . .		Band Resaw, Circular Resaw . . . . .	2.0
	2.0	Edger, Head Rig, Hog, Log Haul . . . . .	2.5
<b>COMPRESSORS</b>		Planer . . . . .	2.0
Centrifugal . . . . .	1.0	Rolls, Non-Reversing . . . . .	2.0
Rotary, Lobe, or Vane . . . . .	2.0	Rolls, Reversing . . . . .	2.5
Rotary, Screw . . . . .	1.25	Sawdust Conveyor . . . . .	1.5
Reciprocating . . . . .	②	Slab Conveyor, Sorting Table . . . . .	2.0
<b>CONVEYORS</b>		<b>OIL INDUSTRY</b>	
Apron, Assembly, Belt, Chain, Flight, Oven . . . . .	1.5	Chiller . . . . .	1.0
Reciprocating . . . . .	②	<b>POWER INDUSTRY</b>	
Screw . . . . .	1.25	Ash Handling Conveyors . . . . .	1.5
<b>CRANES AND HOISTS</b>		Baghouse Air Handling Fans . . . . .	1.5
Main Hoist – Medium Duty . . . . .	2.0	Ball Mill . . . . .	2.5
Main Hoist – Heavy Duty . . . . .	2.5	Belt Conveyors . . . . .	1.5
Skip Hoist . . . . .	2.0	Circulating pumps (centrifugal) . . . . .	1.0
Bridge, Travel or Trolley . . . . .	2.0	Coal Grinders and Crushers . . . . .	2.5
<b>DREDGES</b>		Coal Pulverizers and Hammermills . . . . .	2.5
Cable Reel, Conveyor . . . . .	2.0	Cooling Tower Fans . . . . .	2.0
Cutter Head Drive, Jig Drive . . . . .	3.0	FGD Slurry Pumps (centrifugal) . . . . .	1.0
Pump, Screen, Drive, Stacker, Utility Winch . . . . .	2.0	Forced Draft Fan and Induced Draft Fan . . . . .	1.5
<b>DYNAMOMETER</b> . . . . .		Primary Air, Recycling Fans . . . . .	1.5
	1.0	Traveling Water Screens . . . . .	1.0
<b>ELEVATORS</b>		<b>PULP &amp; PAPER MILLS</b>	
Bucket, Freight . . . . .	2.5	Agitator . . . . .	1.5
<b>EXCITER, GENERATOR</b> . . . . .		Barking Drum . . . . .	3.0
	1.0	Beater and Pulper . . . . .	2.0
<b>EXTRUDER, PLASTIC</b> . . . . .		Bleacher . . . . .	1.0
	2.0	Calendar . . . . .	2.5
<b>FANS</b>		Chipper . . . . .	3.5
Centrifugal . . . . .	1.0	Couch, Cylinder Dryer . . . . .	2.0
Cooling Tower . . . . .	2.0	Felt Stretcher . . . . .	1.0
Forced Draft and Induced Draft . . . . .	1.5	Fourdrinier . . . . .	2.0
Large Mine . . . . .	2.0	Jordan . . . . .	2.5
Propeller . . . . .	1.5	Press . . . . .	2.5
<b>GENERATORS</b>		Pulp Grinder . . . . .	2.5
Even Load . . . . .	1.0	Stock Chests . . . . .	1.5
Hoist or Railway Service . . . . .	2.0	Stock Pump . . . . .	
Welder Load . . . . .	2.5	Centrifugal . . . . .	1.0
<b>PRINTING PRESS</b> . . . . .		Reciprocating . . . . .	2.5
	2.0	Rotary . . . . .	2.0
<b>PUMPS</b>		Suction Roll . . . . .	2.5
Centrifugal . . . . .	1.0	Winder . . . . .	2.0
Positive Displacement . . . . .	1.5	<b>RUBBER INDUSTRY</b>	
Rotary – Gear, Lobe, Vane . . . . .	1.5	Banbury Mixer . . . . .	3.0
Reciprocating . . . . .	②	Calendar . . . . .	2.5
Progressive Cavity . . . . .	1.25	Cracker, Mix Mill, Plasticator, Refiner, Sheeter, Tire Building Machine . . . . .	2.0
Peristaltic . . . . .	1.5	Tire and Tube Press Opener . . . . .	1.0
<b>SCREENS</b>		Tiber and Strainer . . . . .	2.0
Air Washing . . . . .	3.0	Warming Mill . . . . .	2.5
Grizzly . . . . .	1.0	Washer . . . . .	3.0
Coal and Sand (Rotary) . . . . .	2.0	<b>STEEL INDUSTRY</b>	
Vibrating . . . . .	5.0	Coilers . . . . .	2.0
<b>SEWAGE DISPOSAL EQUIPMENT</b> . . . . .		Draw Benches . . . . .	2.0
	1.5	Edger Drives . . . . .	2.0
<b>STOKER</b> . . . . .		Reel Drives . . . . .	2.0
	1.5	Runout Tables (Non-Reversing) . . . . .	3.0
<b>Industry Application</b>		Runout Tables (Reversing) . . . . .	4.5
<b>Typical Service Factor</b>		Soaking Pit Cover Drives . . . . .	3.0
<b>AGGREGATE PROCESSING, CEMENT</b>		Tube Conveyor Rolls . . . . .	2.5
Concrete Mixers . . . . .	2.0	Wire Drawing . . . . .	2.0
Crushers, Ore or Stone . . . . .	3.0	<b>TEXTILE MILLS</b>	
Dryer, Rotary . . . . .	2.0	Batcher, Calendar, Card Machine, Dry Can . . . . .	2.0
Grizzly . . . . .	3.0	Dyeing Machinery . . . . .	1.0
Hammermill . . . . .	2.5	Loom . . . . .	2.0
Mining Kilns . . . . .	2.5	Mangle, Napper, Soaper . . . . .	1.5
Tube, Rod and Ball Mills . . . . .	2.5	Spinner, Tenter Frame . . . . .	2.0
Tumbling Mill or Barrel . . . . .	2.0	<b>BREWERY AND DISTILLING</b>	
<b>BREWERY AND DISTILLING</b>		Bottling and Can Filling Machinery, Brew Kettle, Cooker, Mash Tub . . . . .	1.0
Scale Hopper (frequent peaks) . . . . .	2.0	Scale Hopper (frequent peaks) . . . . .	2.0

① The Service Factors listed are intended only as a general guide and for smooth power sources such as electric motors. For reciprocating prime movers, such as diesel or gas engines, add the following service factor:  
 For 8 or more cylinders, add 0.5  
 For 6 cylinders, add 1.0  
 For 4 cylinders, add 1.5  
 For less than 4 cylinders, consult Rexnord  
 If both driver and driven equipment are reciprocating, consult Rexnord.  
 Add 0.5 to service factor if drive is a hydraulic motor.  
 Omega couplings are not recommended for turbine drives if the coupling cannot be protected from steam leakage or from speeds in excess of the coupling's published speed rating (pages 4-7).  
 ② Consult Rexnord Engineering

**IMPORTANT NOTE** – The coupling selection criteria is intended for the determination of the coupling and style only. It is also recommended that the system be analyzed for torsional and lateral stability using the specific coupling mass-elastic data available from Rexnord. This analysis is the responsibility of the user since the coupling is only a single component in the system.  
**CAUTION** – In the drive systems sensitive to axial movement (i.e. sleeve bearing equipment), it may be necessary to limit axial force and/or displacement. Consult Rexnord for proper installation procedure.

# REXNORD® OMEGA® COUPLINGS

## COUPLING SELECTION

Hub Size	Bore Ranges							
	Straight Bore		TAPER-LOCK® ①			QD® ②		
	② Min. Bore	③ Max. Bore	Bushing Number	Minimum Bore	Maximum Bore	Bushing Number	Minimum Bore	Maximum Bore
2	No Min.	1 <sup>3</sup> / <sub>16</sub>	NA			NA		
3	<sup>3</sup> / <sub>8</sub>	1 <sup>3</sup> / <sub>8</sub>	1008	<sup>1</sup> / <sub>2</sub>	1	NA		
4	<sup>3</sup> / <sub>8</sub>	1 <sup>3</sup> / <sub>4</sub>	1008	<sup>1</sup> / <sub>2</sub>	1	JA	<sup>3</sup> / <sub>8</sub>	1 <sup>1</sup> / <sub>4</sub>
5	<sup>3</sup> / <sub>8</sub>	1 <sup>15</sup> / <sub>16</sub>	1108	<sup>1</sup> / <sub>2</sub>	1	SH	<sup>1</sup> / <sub>2</sub>	1 <sup>11</sup> / <sub>16</sub>
10	<sup>3</sup> / <sub>8</sub>	2 <sup>1</sup> / <sub>4</sub>	1310	<sup>1</sup> / <sub>2</sub>	1 <sup>3</sup> / <sub>8</sub>	SDS	<sup>1</sup> / <sub>2</sub>	2
20	<sup>3</sup> / <sub>4</sub>	2 <sup>3</sup> / <sub>4</sub>	1610	<sup>1</sup> / <sub>2</sub>	1 <sup>5</sup> / <sub>8</sub>	SK	<sup>1</sup> / <sub>2</sub>	2 <sup>1</sup> / <sub>2</sub>
30	<sup>3</sup> / <sub>4</sub>	3 <sup>1</sup> / <sub>4</sub>	2012	<sup>1</sup> / <sub>2</sub>	2	SF	<sup>1</sup> / <sub>2</sub>	2 <sup>13</sup> / <sub>16</sub>
40	<sup>3</sup> / <sub>4</sub>	3 <sup>3</sup> / <sub>4</sub>	2517	<sup>1</sup> / <sub>2</sub>	2 <sup>1</sup> / <sub>2</sub>	E	<sup>7</sup> / <sub>8</sub>	3 <sup>1</sup> / <sub>2</sub>
50	1 <sup>1</sup> / <sub>8</sub>	4	2517	<sup>1</sup> / <sub>2</sub>	2 <sup>1</sup> / <sub>2</sub>	E	<sup>7</sup> / <sub>8</sub>	3 <sup>1</sup> / <sub>2</sub>
60	1 <sup>1</sup> / <sub>8</sub>	4 <sup>1</sup> / <sub>2</sub>	3020	1 <sup>5</sup> / <sub>16</sub>	3	F	1	3 <sup>15</sup> / <sub>16</sub>
70	1 <sup>3</sup> / <sub>8</sub>	4 <sup>7</sup> / <sub>8</sub>	3535	1 <sup>3</sup> / <sub>16</sub>	3 <sup>1</sup> / <sub>2</sub>	J	1 <sup>7</sup> / <sub>16</sub>	4 <sup>1</sup> / <sub>2</sub>
80	1 <sup>7</sup> / <sub>8</sub>	6 <sup>3</sup> / <sub>4</sub>	4040	1 <sup>7</sup> / <sub>16</sub>	4	M	1 <sup>15</sup> / <sub>16</sub>	5 <sup>1</sup> / <sub>2</sub>
100	1 <sup>7</sup> / <sub>8</sub>	7 <sup>1</sup> / <sub>4</sub>	4545	1 <sup>15</sup> / <sub>16</sub>	4 <sup>1</sup> / <sub>2</sub>	M	1 <sup>15</sup> / <sub>16</sub>	5 <sup>1</sup> / <sub>2</sub>
120	1 <sup>7</sup> / <sub>8</sub>	8 <sup>1</sup> / <sub>4</sub>	5050	2 <sup>5</sup> / <sub>16</sub>	5	N	2 <sup>7</sup> / <sub>16</sub>	6
140	1 <sup>7</sup> / <sub>8</sub>	9 <sup>1</sup> / <sub>4</sub>	7060	4 <sup>9</sup> / <sub>16</sub>	7	P	2 <sup>15</sup> / <sub>16</sub>	7

① Bushings are not included with bushed hubs. Bushing bore ranges may vary, check with bushing manufacturer.

② Rough bores are slightly undersized to conform with minimum bore specifications.

③ With shallow keyway

Omega	Dodge Para-Flex	Lovejoy (Rubber)	TB Woods (Rubber)	Falk Grid			Kop-Flex Gear
				1000T	10T	F	
2		L-095	5	1020T	20T	3	1H
3		L-099, L-100	6	1030T	30T	4	1H
4		L-110	7	1040T	40T	4	1H
5	50	L-110	8	1040T, 1050T	40T, 50T	5, 6	1H, 1 <sup>1</sup> / <sub>2</sub> H
10	60	L-150, L-190	9	1050T, 1060T	50T, 60T	7, 8	1 <sup>1</sup> / <sub>2</sub> H
20	70	L-225	10	1060T, 1070T	60T, 70T	8, 9	1 <sup>1</sup> / <sub>2</sub> H, 2H
30	80	L-276	11	1070T, 1080T	70T, 80T	9, 10	2H, 2 <sup>1</sup> / <sub>2</sub> H
40	90		12	1090T	90T	10	2 <sup>1</sup> / <sub>2</sub> H
50	110			1090T	90T	11	2 <sup>1</sup> / <sub>2</sub> H
60	120		13	1090T	90T	11	2 <sup>1</sup> / <sub>2</sub> H
70	140		14	1100T	100T	13	3H
80	160		16	1110T	110T	14	3H
100	200		NA	1120T	120T	15	⑤
120	240		NA	1130T, 1140T	130T, 140T	16, 17	⑤
140	280		NA	1150T	150T	18	⑤

④ CAUTION should be applied when using any interchange chart (particularly with respect to gear and grid couplings) since each product has different dimensions, benefits and service factor recommendations. This interchange is based on typical specifications for centrifugal pump applications at 1750 RPM. For specific applications, consult Rexnord, refer to page 12, or ask for our free Slide Selector. Use this chart as a general guide.

⑤ Consult Rexnord.

**BORE SPECIFICATION**

Couplings will be bored in accordance with AGMA Standard 9002-A86 for flexible couplings. Finished bore hubs will be Class 1 clearance fit unless otherwise specified.

**Bore Sizes**

Shaft Dia.	Class 1 Clearance Fit	Interference Fit	Shaft Dia.	Class 1 Clearance Fit	Interference Fit
1/2	.500-.501	.4990-.4995	2 3/8	2.3750-2.3765	2.373-2.374
5/8	.625-.626	.6240-.6245	2 1/2	2.5000-2.5015	2.498-2.499
3/4	.750-.751	.7490-.7495	2 5/8	2.6250-2.6265	2.623-2.624
7/8	.875-.876	.8740-.8745	2 3/4	2.7500-2.7515	2.748-2.749
1	1.000-1.001	.9990-.9995	2 7/8	2.8750-2.8765	2.873-2.874
1 1/8	1.125-1.126	1.1240-1.1245	3	3.0000-3.0015	2.998-2.999
1 1/4	1.250-1.251	1.2490-1.2495	3 1/4	3.2500-3.2515	3.2470-3.2485
1 3/8	1.375-1.376	1.3740-1.3745	3 1/2	3.5000-3.5015	3.4970-3.4985
1 1/2	1.500-1.501	1.4990-1.4995	3 5/8	3.6250-3.6265	3.6220-3.6235
1 5/8	1.625-1.626	1.623-1.624	3 3/4	3.7500-3.7515	3.7470-3.7485
1 3/4	1.750-1.751	1.748-1.749	4	4.0000-4.0015	3.9970-3.9985
1 7/8	1.875-1.876	1.873-1.874	4 1/2	4.500-4.502	4.4965-4.4980
2	2.000-2.001	1.998-1.999	5	5.000-5.002	4.9965-4.9980
2 1/8	2.1250-2.1265	2.123-2.124	5 1/2	5.500-5.502	5.4960-5.4975
2 1/4	2.2500-2.2515	2.248-2.249	6	6.000-6.002	5.9960-5.9975

Consult Rexnord for unlisted sizes or bores over 6-inch diameter.

**Bore Sizes**

Nominal Shaft Diameter	Keyway				Setscrew Dia. Class 2B NC Thread	Recommended Tightening Torque (In. Lbs.)
	Over	Thru	Width	Depth		
				Sq. Rect.		
5/16	7/16	3/32	3/64	—	1/4-20	87
7/16	9/16	1/8	1/16	3/64		
9/16	7/8	3/16	3/32	1/16		
7/8	1 1/4	1/4	1/8	3/32	3/8-16①	290
1 1/4	1 3/8	5/16	5/32	1/8		
1 3/8	1 3/4	3/8	3/16	1/8		
1 3/4	2 1/4	1/2	1/4	3/16	1/2-13②	620
2 1/4	2 3/4	5/8	5/16	7/32	5/8-11	1325
2 3/4	3 1/4	3/4	3/8	1/4	3/4-10	2400
3 1/4	3 3/4	7/8	7/16	5/16	7/8-9	5200
3 3/4	4 1/2	1	1/2	3/8	1-8	7200
4 1/2	5 1/2	1 1/4	5/8	7/16		
5 1/2	6 1/2	1 1/2	3/4	1/2		
6 1/2	7 1/2	1 3/4	7/8	3/4		
7 1/2	9	2	1	3/4		

- ① Maximum setscrew diameter is 1/4-20 UNC for size #2 hub.
- ② Maximum setscrew size for hub sizes #3 thru #10 is 3/8-16 UNC.

**FINISHED STOCK BORE HUBS AVAILABLE (listed by part number)**

(STRAIGHT BORE HUBS BORED IN ACCORDANCE WITH AGMA STANDARD 9002 - A86 CLASS 1 CLEARANCE FIT)

Size Bore	2HSB	3HSB	4HSB	5HSB	10HSB	20HSB	30HSB	40HSB
3/4	7390419	7390423						
7/8	7390420	7390424	7390429					
1	7390421	7390425	7390430					
1 1/8	7390422	7390426	7390431	7390434	7390438	7300379		
1 1/4		7390427				7300380		
1 3/8		7390428	7390432	7390435	7390439	7300384		
1 1/2						7300383		
1 5/8			7390433	7390436	7390440	7300385	7300407	7300432
1 3/4						7300388		
1 7/8				7390437	7390441	7300390	7300410	7300435
2						7300343	7300445	
2 1/8						7300395	7300415	
2 3/8						7300400	7300420	7300445
2 3/4							7300446	
2 7/8							7300425	
3 3/8								7300455

**Omega Misalignment Capacity**

Coupling Size	Hub Dia. "D" In.	Max Parallel Offset	Angular ③						
			1/4°	1/2°	1°	1 1/2°	2°	3°	4.0°
2	1 7/8"	0.0625	0.008	0.016	0.032	0.048	0.064	0.096	0.128
3	2 5/16"	0.0625	0.010	0.020	0.040	0.060	0.080	0.120	0.160
4	2 5/8"	0.0625	0.012	0.024	0.048	0.072	0.096	0.144	0.196
5	3 1/8"	0.0625	0.014	0.028	0.056	0.084	0.112	0.168	0.224
10	3 5/8"	0.0625	0.016	0.032	0.064	0.096	0.128	0.192	0.256
20	4 1/2"	0.0938	0.020	0.040	0.080	0.120	0.160	0.240	—
30	5 7/16"	0.0938	0.024	0.048	0.096	0.144	0.192	0.288	—
40	6 5/8"	0.0938	0.029	0.058	0.116	0.174	0.232	0.348	—
50	8 1/8"	0.0938	0.036	0.072	0.144	0.216	0.288	0.432	—
60	8 3/4"	0.125	0.038	0.076	0.152	0.228	0.304	—	—
70	9 1/2"	0.125	0.042	0.084	0.168	0.252	0.336	—	—
80	11 1/4"	0.125	0.049	0.098	0.196	0.294	0.392	—	—
100	14 1/8"	0.1875	0.062	0.124	0.248	0.372	—	—	—
120	17 5/8"	0.1875	0.077	0.154	0.308	0.462	—	—	—

③ T.I.R. Variation in gap between hub faces. Based on 0.01745 inches per inch of Dia. "D" per degree of misalignment.

# REXNORD® OMEGA® COUPLINGS

## ORDERING INSTRUCTIONS

### STANDARD AND SPACER COUPLINGS

When ordering a complete coupling, specify size/type of element and hubs (two hubs per complete coupling) options include:

#### Element

- [E2 – E140] standard (close coupled)
- [ES2-R – ES80] spacer

#### Hub

- [2HRB – 140HRB] straight hub-rough bore
- [2HSB – 60HSB] straight hub-stock bore (specify bore size from table on page 15)
- [2HCB – 140HCB] straight hub-custom bore (specify bore and keyway)
- [4HQD – 140HQD] hub-QD (bushing not included)
- [3HTL – 140HTL] hub-TAPER-LOCK® (bushing not included)
- [10HMM – 140HMM] straight hub-mill motor (specify mill motor number, rough or custom bore)

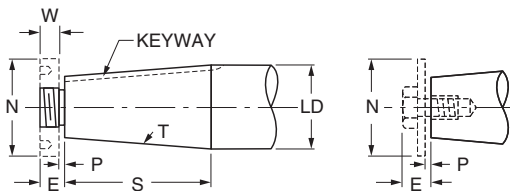
#### Order Example:

Complete E50 standard (close coupled) coupling with one finished bore 2 1/8" hub w/standard keyway and one QD hub less bushing.  
 Order description:  
 1 ea. E50 element  
 1 ea. 50HSB – 2 1/8" – std.  
 1 ea. 50 HQD – steel

## TAPERED BORES

### INFORMATION REQUIRED

- Drawing of HUB showing complete bore and keyway details.
- OR —  
 Drawing of SHAFT with dimensions shown below, allowing Rexnord to bore hubs to suit.



- (LD) Large Diameter, Specify in Decimals.
- (S) Length of Taper, Measure parallel to Shaft centerline.
- (T) Taper per Foot, Difference in Diameter in one foot length.
- (P) Clearance space for drawing Hub up on tapered shaft. Usually 1/8" or 1/4", depending on shaft size and taper.

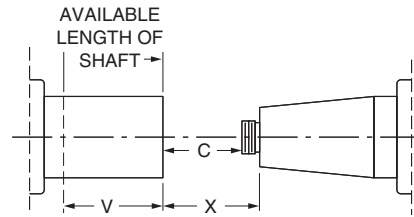
Keyway: Width, Depth.

Note: Specify if keyway is parallel to Taper or if parallel to shaft center line.  
 Specify depth at larger diameter of Taper if keyway is parallel to shaft center line.

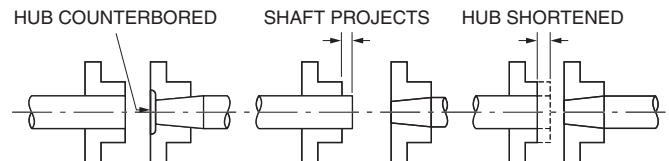
### SUPPLEMENTAL TAPER BORE INFORMATION

With connected equipment in fixed position, the following additional information is necessary:

Dimensions "V" and "X" must be given when one or both connected machines are fixed on their bases. Advise if dimension "X" is fixed, or if variable between what limits.



A fixed "X" dimension may require altered or special coupling hubs. Often the straight bored hub can be positioned on its shaft allowing the use of a standard coupling. See illustrations below.



Consult A.G.M.A. Standard 9002-A86 "Taper Bores for Flexible Couplings" for new applications.



**THIS PAGE INTENTIONALLY LEFT BLANK**

# World Class Customer Service

For more than 100 years, the dedicated people of Rexnord have delivered excellence in quality and service to our customers around the globe. Rexnord is a trusted name when it comes to providing skillfully engineered products that improve productivity and efficiency for industrial applications worldwide. We are committed to exceeding customer expectations in every area of our business: product design, application engineering, operations, and customer service.

Because of our customer focus, we are able to thoroughly understand the needs of your business and have the resources available to work closely with you to reduce maintenance costs, eliminate redundant inventories and prevent equipment down time.

Rexnord represents the most comprehensive portfolio of power transmission and conveying components in the world with the brands you know and trust.

Omega and Rexnord are registered trademarks of Rexnord Industries, LLC. Falk is a trademark of Rexnord. Dodge, Paraflex, Lovejoy, TB Woods, and Kopflex are trademarks of their respective companies. Taper-Lock is a trademark of a bushing under license. All rights reserved.

## WORLDWIDE CUSTOMER SERVICE

### AUSTRALIA

Rexnord Australia Pty. Ltd.  
Picton, New South Wales  
Phone: 61-2-4677-3811  
Fax: 61-2-4677-3812

### BRAZIL

Rexnord Correntes Ltda.  
Sao Leopoldo - RS  
Phone: 55-51-579-8022  
Fax: 55-51-579-8029

### CANADA

Rexnord Canada Ltd.  
Scarborough, Ontario  
Phone: 1-416-297-6868  
Fax: 1-416-297-6873

### CHINA

Rexnord China  
Shanghai, China  
Phone: 86-21-62701942  
Fax: 86-21-62701943

### EUROPE

Rexnord NV/SA  
Mechelen, Belgium  
Phone: 32-15-443811  
Fax: 32-15-443860

Rexnord Kette GmbH  
Betzdorf, Germany  
Phone: 49-2741-2840  
Fax: 49-2741-284-385

### LATIN AMERICA

Rexnord International, Inc.  
Milwaukee, Wisconsin  
Phone: 1-414-643-2366  
Fax: 1-414-643-3222  
E-mail: international2@rexnord.com

### MEXICO

Rexnord S.A. de C.V.  
Queretaro, Qro.  
Phone: 52-442-218.5000  
Fax: 52-442-218-1090

### SINGAPORE

Rexnord International, Inc.  
Singapore City, Singapore  
Phone: 65-6338-5622  
Fax: 65-6338-5422

### UNITED STATES

Customer Service  
Phone: 1-866-REXNORD  
(1-866-739-6673)  
Fax: 1-614-675-1898  
E-mail: rexnordcs(state)@rexnord.com  
Example: rexnordcsohio@rexnord.com

### ALL COUNTRIES NOT LISTED

Rexnord International  
Milwaukee, Wisconsin  
Phone: 1-414-643-2366  
Fax: 1-414-643-3222  
E-mail: international1@rexnord.com

