

1 Instructions

Finger guards fit over the soft starter's power terminals to increase IP rating and prevent accidental contact with live terminals.



CAUTION

Remove mains and control voltage from the soft starter before attaching or removing accessories.

1.1 Rubber Finger Guards Installation

Rubber finger guards are available for use with IP00 soft starters up to 220 A. Rubber finger guards provide IP20 protection when used with cable of diameter 22 mm or greater. Install the finger guards using the following procedure:

1. Place three finger guards side-by-side in one retaining bracket. Align the assembly so that the screw holes in the bracket match the screw holes in the soft starter.
Compact Soft Starter only: Remove the top two screws from the plastic panel around the power terminals.
2. Feed each power cable through the narrow end of each finger guard. Connect the cables to the appropriate terminals on the soft starter.
3. If the cables do not fit through the finger guards, shorten the finger guards at the narrow end to make a bigger opening.
4. Screw the retaining bracket to the soft starter.
Compact Soft Starter only: Use the screws from step 1 to attach the retaining bracket to the soft starter casing.
5. Repeat steps 1 to 4 for the other set of terminals.

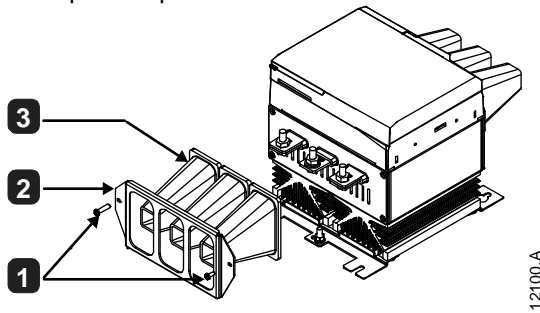

Compact Soft Starter

12100.A

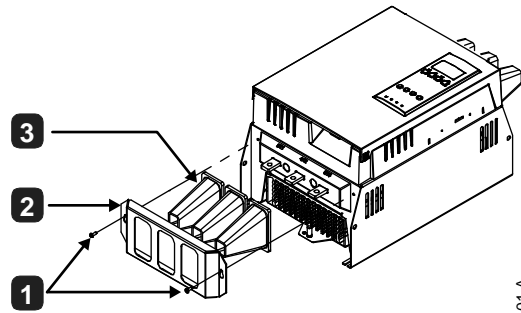

Advanced Soft Starter

12101.A

1	Screws
2	Retaining bracket

3	Finger guards
---	---------------

